



# MECHANICS

## Lecture No.2

د. محمد سعد



# Moment

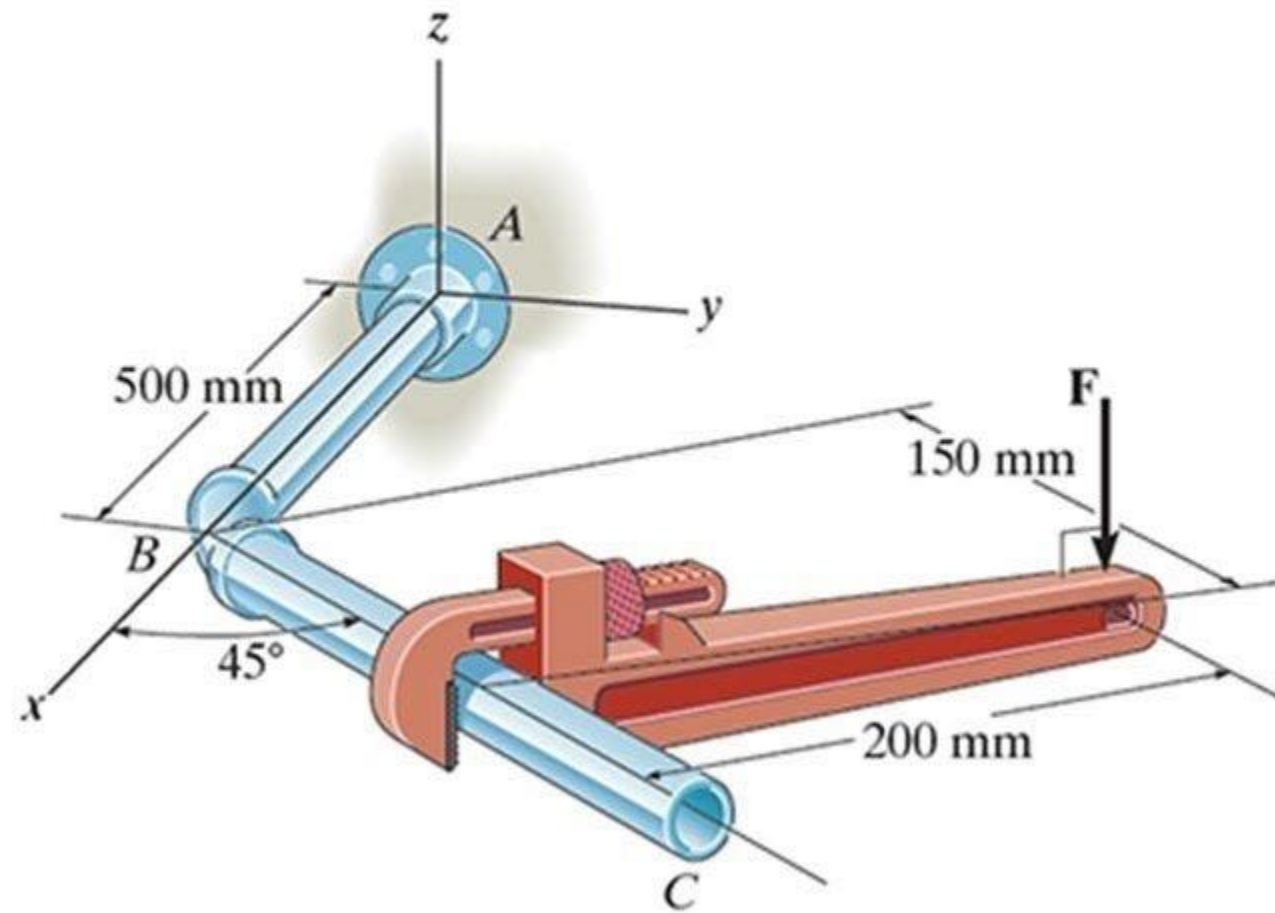

# Couple

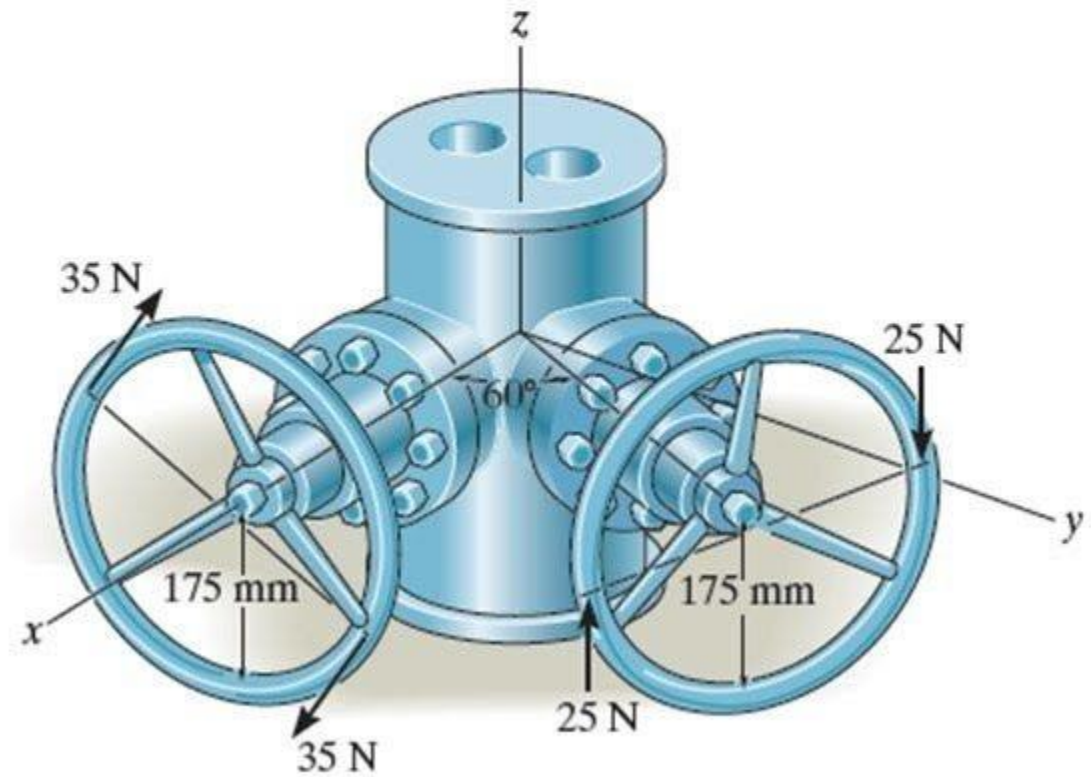

# Principle of Moment

When a force is applied on a body it will produce a tendency for the body to rotate about a point that is not on the line of action of the force. In figure shown below (a), spanner used to unscrew the bolt, if a force applied to the handle of the spanner it will tend to turn the bolt about point O or the Z axis. **The moment of a force is a measure of its tendency to rotate an object about some point.** If the force F is applied along the spanner its will not tend to turn the bolt as figure shown below (b).

## 1. Magnitude of the moment:

$$M_O = F * d$$

**M**: moment about point **O**

**F**: magnitude of the force

**d** :the perpendicular distance from the axis of point **O** to the line of action of the force **F**.

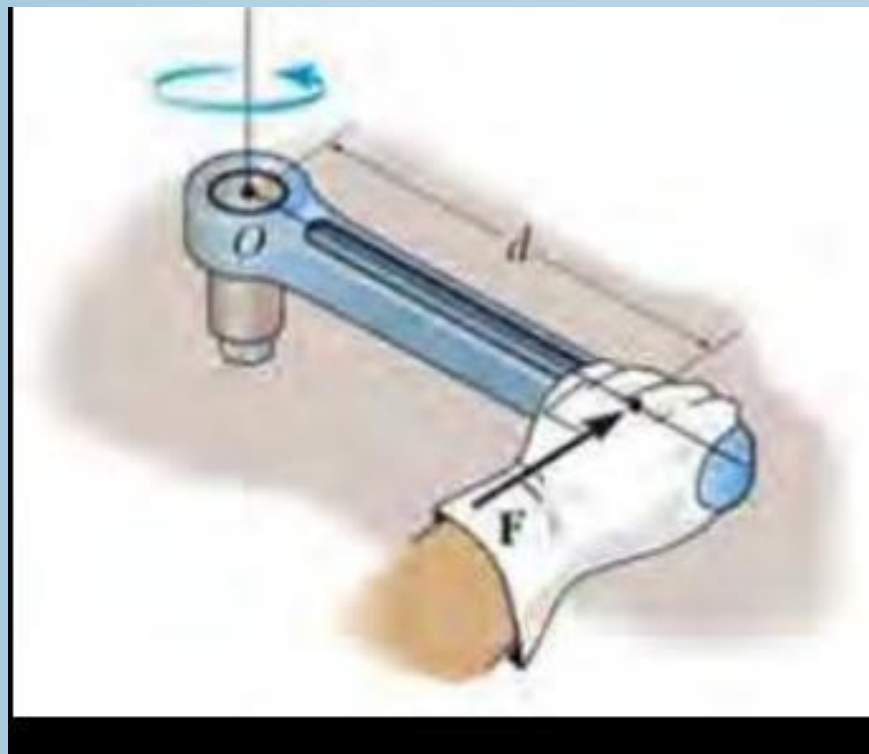

(a)

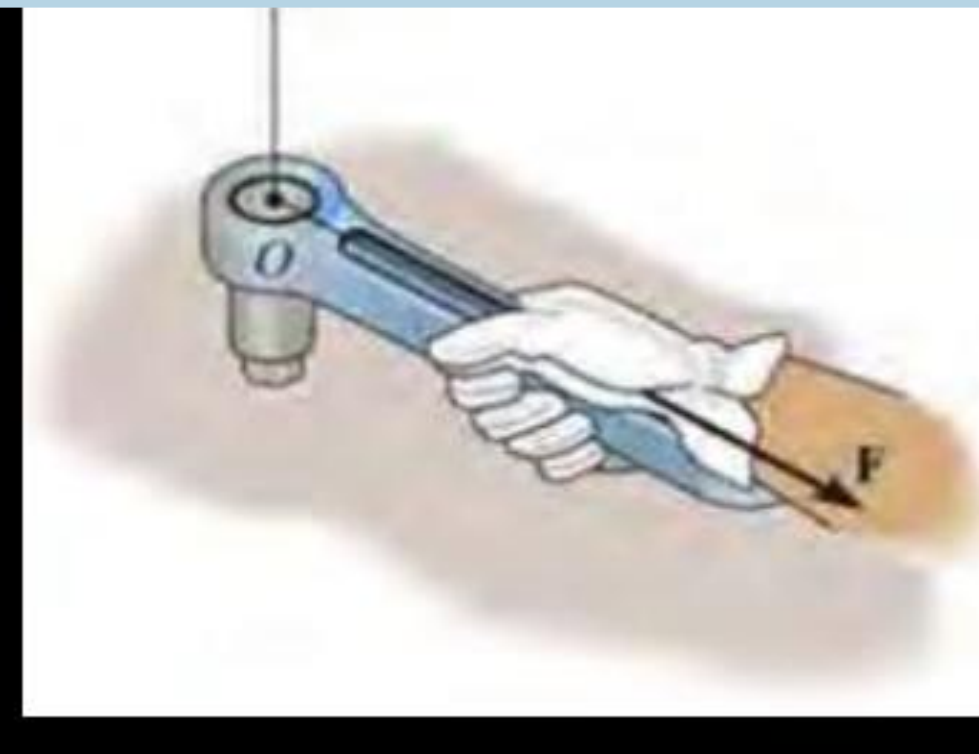

(b)

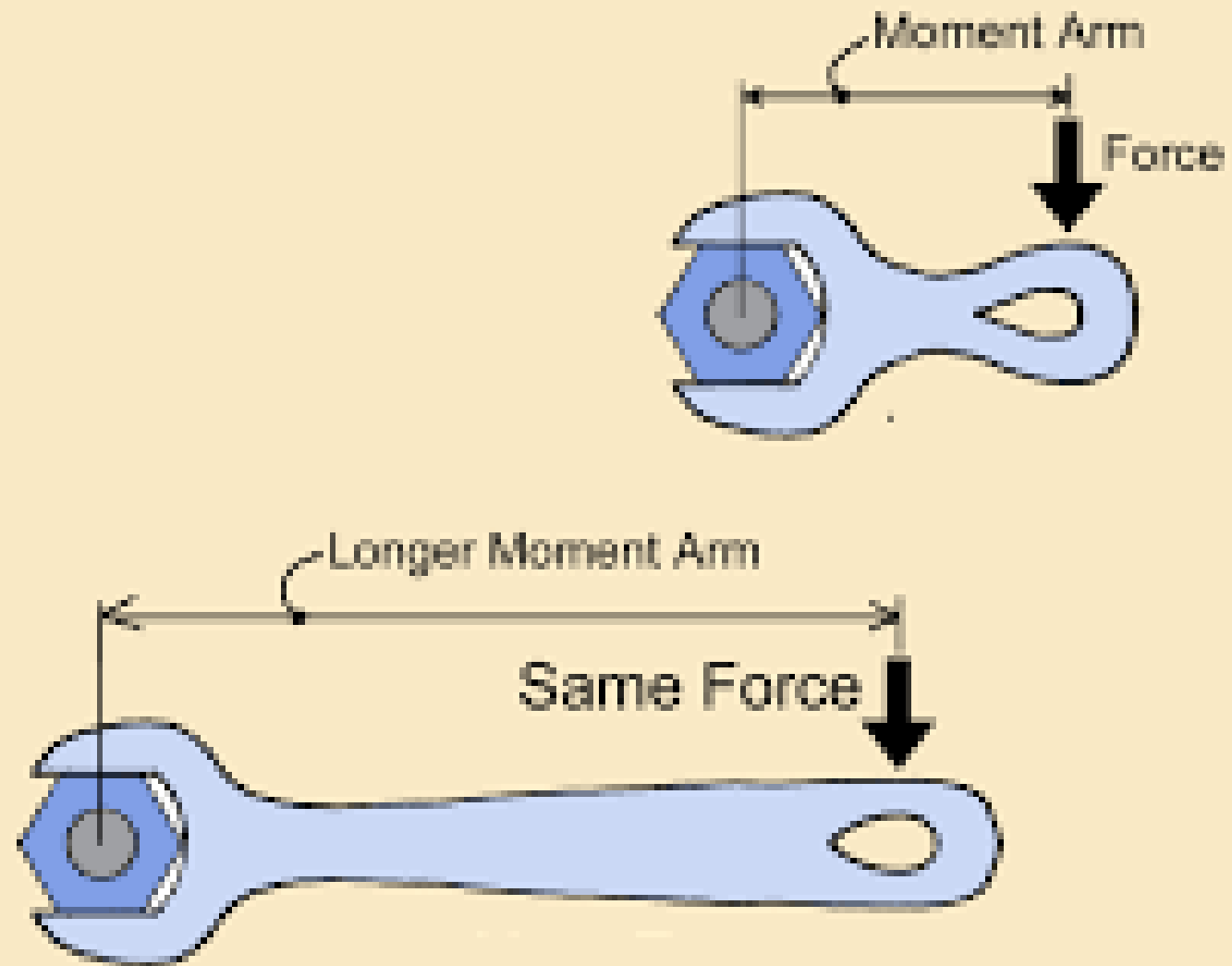



## 2. Direction of the moment:

- a. The moment will be positive if the rotation with clockwise
- b. The moment will be negative if the rotation counterclockwise

Example (1): Determine the moment of the force in fig. 1 for cases a, b and c

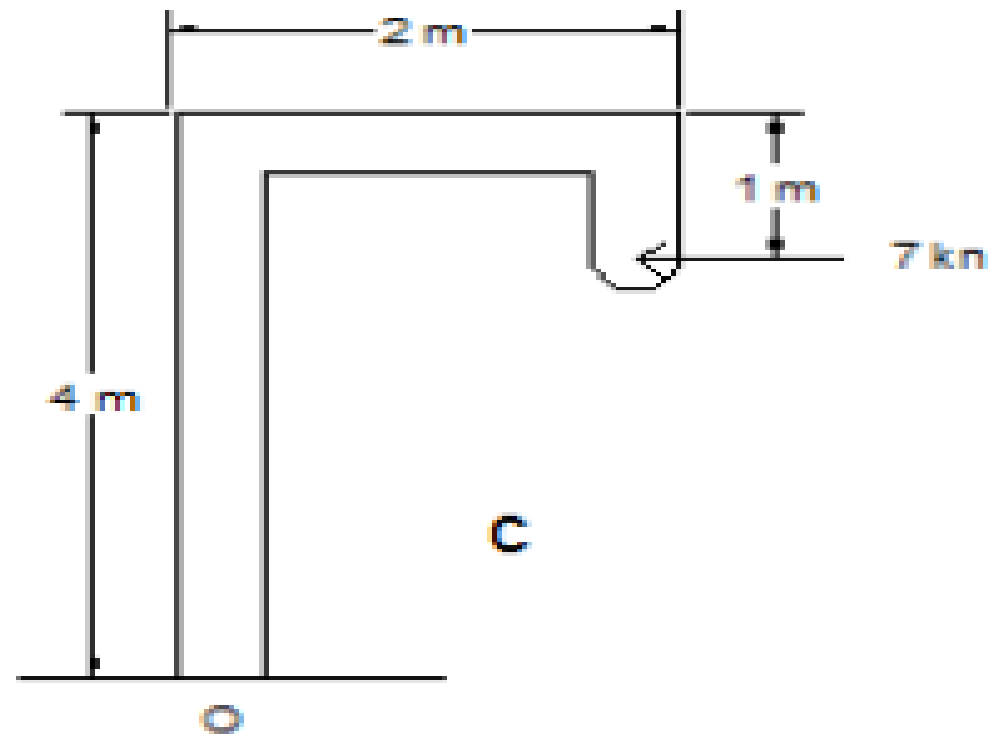
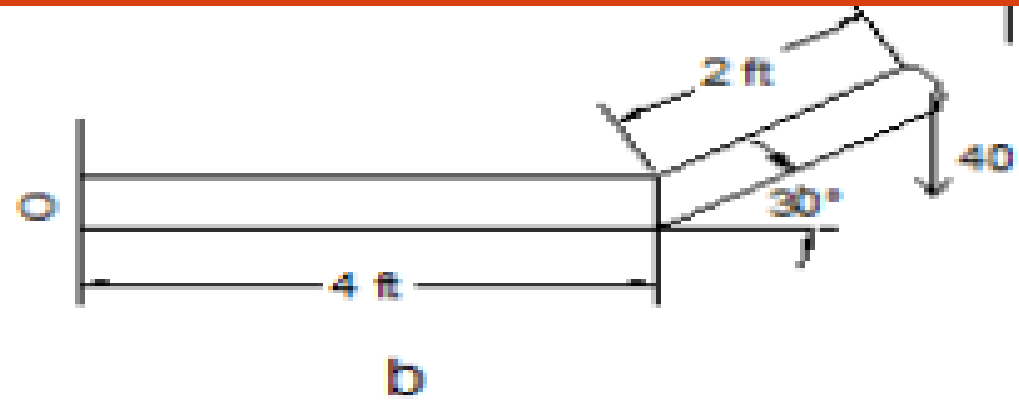
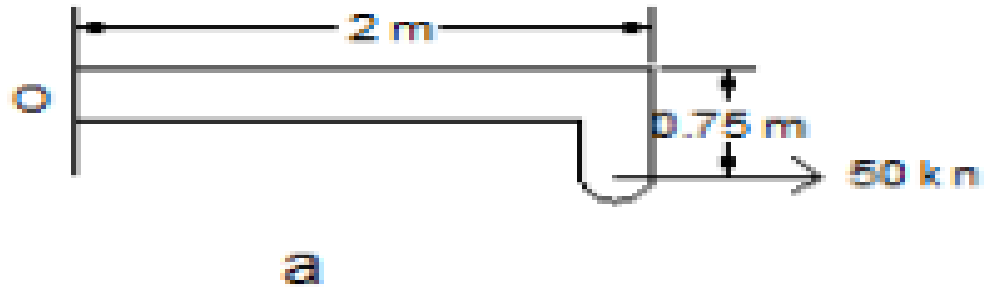

**Sol.**

**Case a**

$$**M_0 = F * d**$$

$$**M_0 = 50 * 0.75 = -37.5 kn. m**$$

**Case b**

$$**M_0 = F * d**$$

$$**M_0 = 40 * (4 + 2\cos30) = 229.3 lb. ft**$$

**Case c**

$$**M_0 = F * d**$$

$$**M_0 = 7 * (4 - 1) = -21 kn. m**$$

A 100-lb vertical force is applied to the end of a lever, which is attached to a shaft at  $O$ . Determine (a) the moment of the 100-lb force about  $O$ ; (b) the horizontal force applied at  $A$  that creates the same moment about  $O$ ; (c) the smallest force applied at  $A$  that creates the same moment about  $O$ ; (d) how far from the shaft a 240-lb vertical force must act to create the same moment about  $O$ ; (e) whether any one of the forces obtained in parts  $b$ ,  $c$ , or  $d$  is equivalent to the original force.

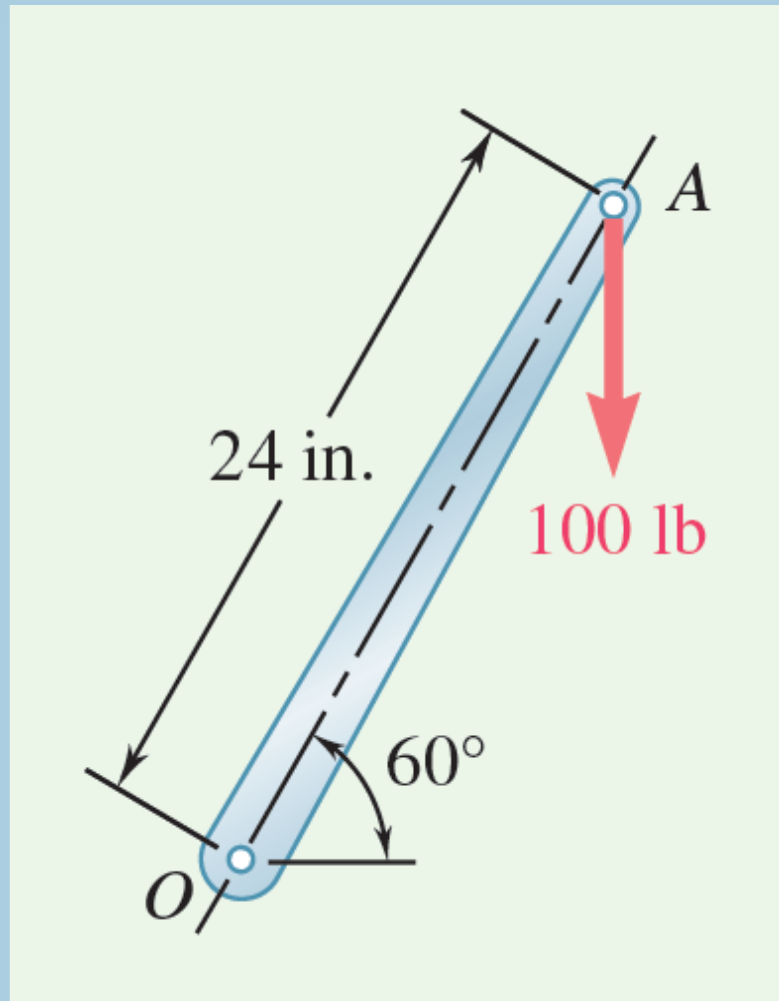

$$d = (24 \text{ in.}) \cos 60^\circ = 12 \text{ in.}$$

The magnitude of the moment about  $O$  of the 100-lb force is

$$M_o = Fd = (100 \text{ lb})(12 \text{ in.}) = 1200 \text{ lb} \cdot \text{in.}$$

**b. Horizontal Force.** In this case, you have (Fig. 2)

$$d = (24 \text{ in.}) \sin 60^\circ = 20.8 \text{ in.}$$

Because the moment about  $O$  must be  $1200 \text{ lb} \cdot \text{in.}$ , you obtain

$$M_o = Fd$$

$$1200 \text{ lb} \cdot \text{in.} = F(20.8 \text{ in.})$$

$$F = 57.7 \text{ lb}$$

**c. Smallest Force.** Because  $M_o = Fd$ , the smallest value of  $F$  occurs when  $d$  is maximum. Choose the force perpendicular to  $OA$  and note that  $d = 24 \text{ in.}$

(Fig. 3); thus,

$$M_o = Fd$$

$$1200 \text{ lb} \cdot \text{in.} = F(24 \text{ in.})$$

$$F = 50 \text{ lb}$$

**d. 240-lb Vertical Force.** In this case (Fig. 4),  $M_o = Fd$  yields

$$1200 \text{ lb} \cdot \text{in.} = (240 \text{ lb}) d \quad d = 5 \text{ in.}$$

but

$$OB \cos 60^\circ = d$$

so

$$OB = 10 \text{ in.} \quad \blacktriangleleft$$

**e.** None of the forces considered in parts *b*, *c*, or *d* is equivalent to the original 100-lb force. Although they have the same moment about *O*, they have different *x* and *y* components. In other words, although each force tends to rotate the shaft in the same direction, each causes the lever to pull on the shaft in a different way.

**REFLECT and THINK:** Various combinations of force and lever arm can produce equivalent moments, but the system of force and moment produces a different overall effect in each case.

### **3. resultant of the moment:**

The resultant moment about point O in the figure shown below can be determined by finding algebraic sum of the moments that caused by all the forces in system.

Example (3): Determine the resultant moment of the four forces acting on the rod in fig. 2

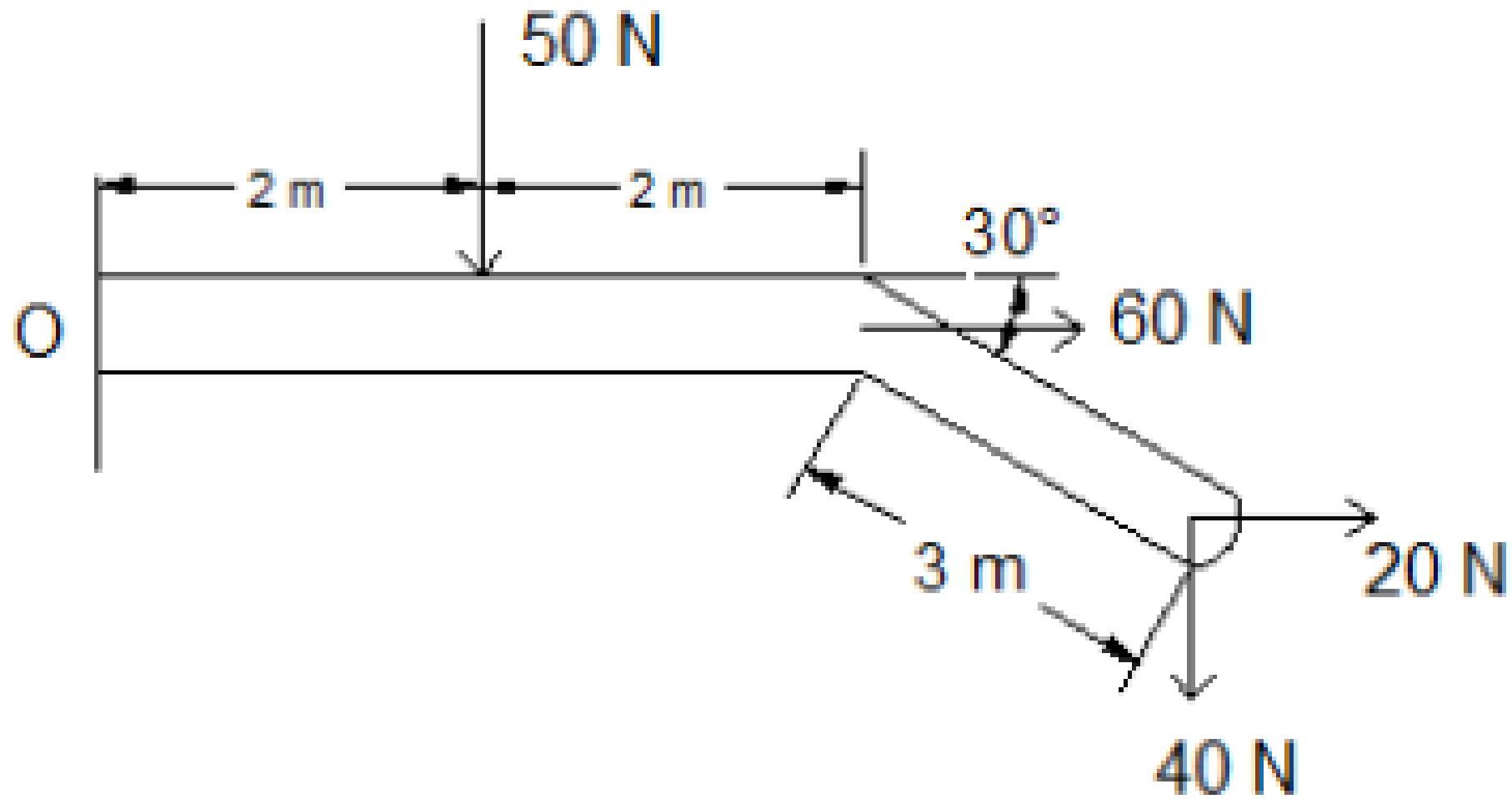

Sol.

$$\mathbf{M}_{R0} = \Sigma \mathbf{F} * \mathbf{d}$$

$$\mathbf{M}_{R0} = (2 * 50) + (40 * (4 + 3 \cos 30)) + (60 * 0) - (20 * 3 \sin 30)$$

$$\mathbf{M}_{R0} = 334 \text{ N. m}$$

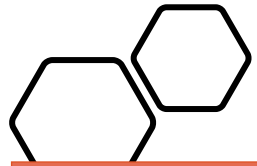

# Moment of a couple

- **A couple** is defined as two parallel force that have the same magnitude and opposite directions and separated by perpendicular distance  $d$ , the moment of the couple is the algebraic sum of the moment of its forces about any axis.

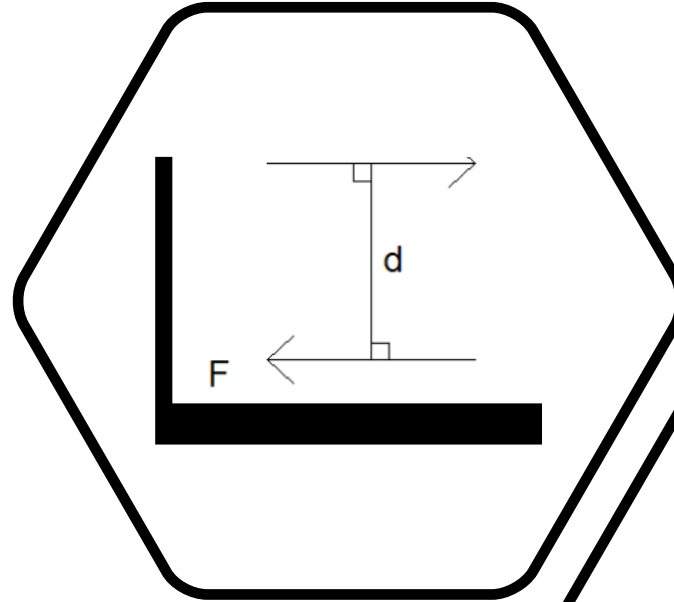

$$M = F * d$$

M: couple moment

F: magnitude of the force

d :the perpendicular distance between the forces.

The couple moment have the same magnitude for all axis perpendicular to the plan, in fig. shown below the couple moment about bc axis and ef axis have same magnitude .

Example (1):Determine the moment of the couple in the fig. 1 with respect to a point, b point and c point.

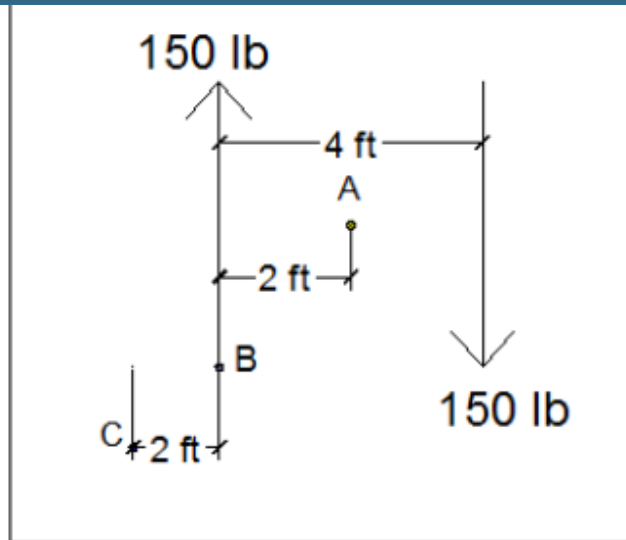

SOL.

$$M_a = 150 * 2 + 150 * 2 = 600 \text{ Ib. ft}$$

$$M_b = 150 * 4 = 600 \text{ Ib. ft}$$

$$M_c = 150 * 6 - 150 * 2 = 600 \text{ Ib. ft}$$

Example (2): Determine the resultant couple moment of the three couples acting on the plate in the fig. 2.

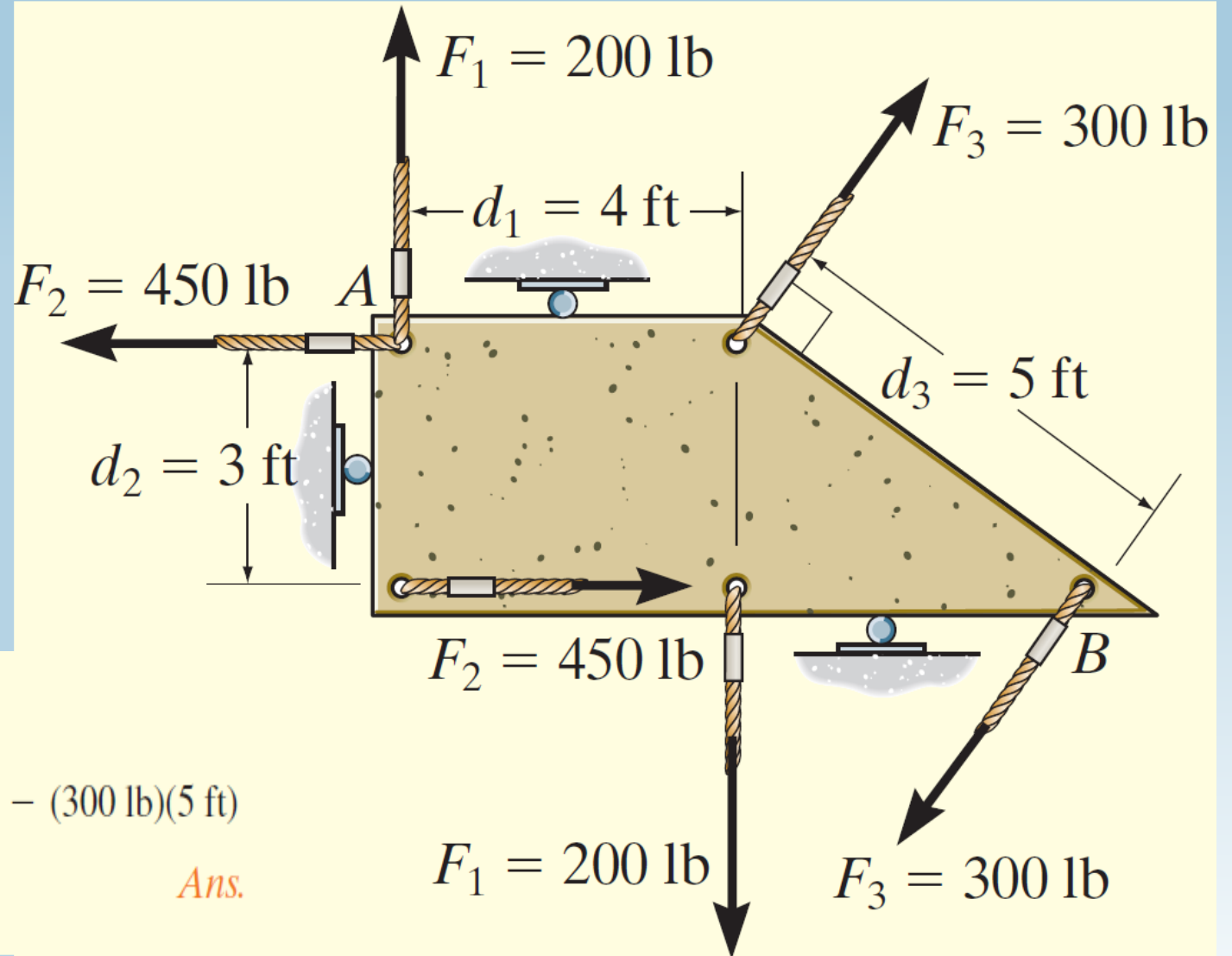

$$\curvearrowright + M_R = \Sigma M; M_R = -F_1 d_1 + F_2 d_2 - F_3 d_3$$

$$= -(200 \text{ lb})(4 \text{ ft}) + (450 \text{ lb})(3 \text{ ft}) - (300 \text{ lb})(5 \text{ ft})$$

$$= -950 \text{ lb} \cdot \text{ft} = 950 \text{ lb} \cdot \text{ft} \curvearrowright$$

*Ans.*

Determine the moment of the force about point  $O$ .

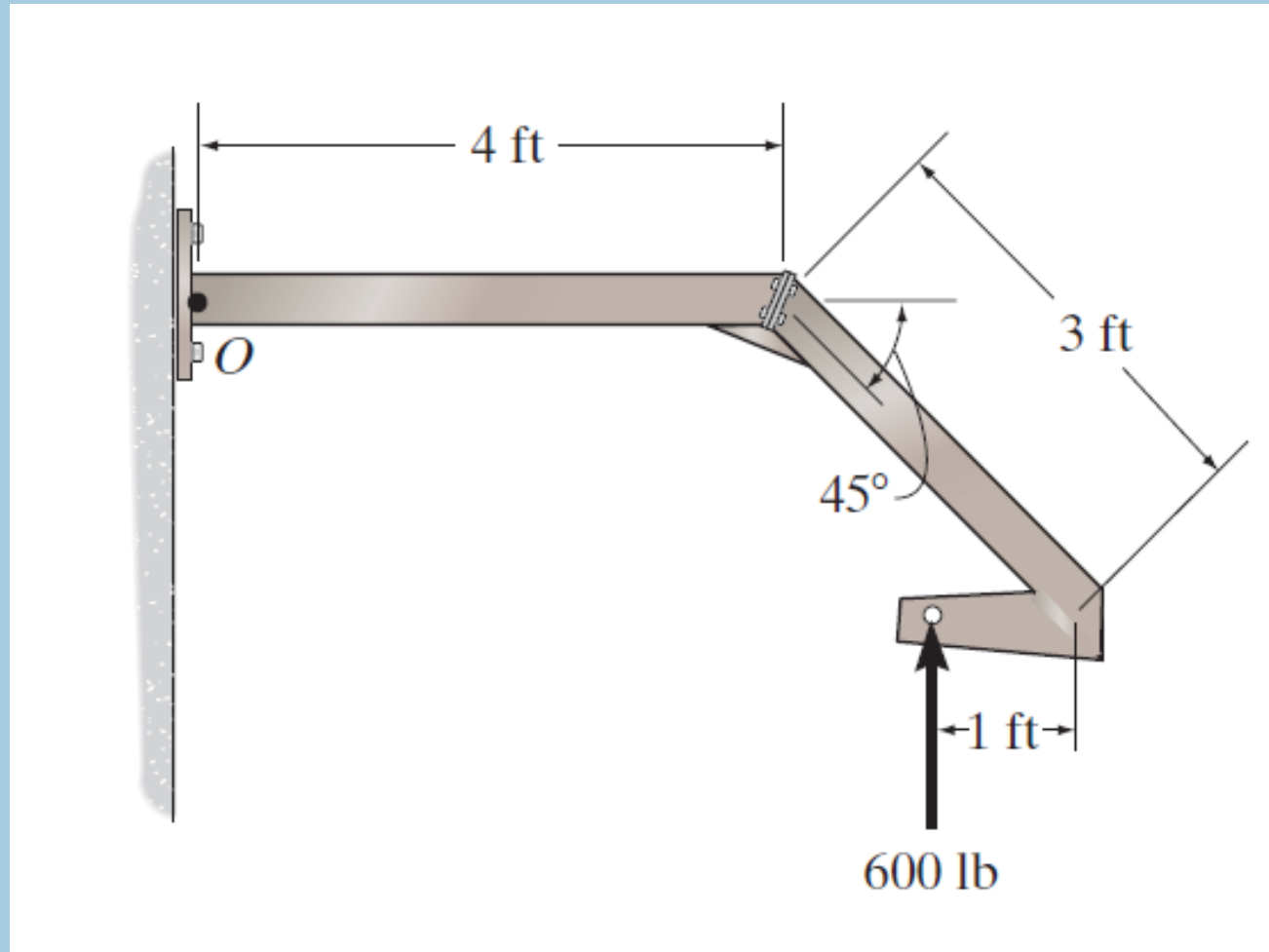

# Thank you for listening

